

Delay Measurement in OTN networks

Apodis Application Note

Leon Bruckman

System Engineering

lbruckman@iplight.com

April 2010

© 2010 IP Light, Inc.

Background.

OTN standardization efforts got under way seeking an optical transport technology that would replace the legacy SONET/SDH infrastructure prevailing in legacy TDM oriented networks.

From the early days of telecommunications it was apparent that maintenance tools were required in order to avoid charging users during down time, and to identify and isolate the fault causing element to support fast and cost effective repair actions. Along with hard-failures detecting tools, soft degradations detecting tools were usually based on BER monitoring and used to detect potential failure sources in the network.

With the advent of QoS sensitive applications and Service Level Agreement (SLA) based services, the ability to monitor the network performance became a critical issue for service providers. The main performance parameters influencing the service performance are BER and delay; different levels of BER-Delay are required for different services. Some services such as file transfer are not sensitive to delay but are somewhat sensitive to BER, others such as voice are less sensitive to BER but are very sensitive to delay, and others such as video conferencing are sensitive to both BER and delay.

OTN provides strong BER monitoring tools. Some of these tools are similar to the ones used in SONET/SDH networks (BIP), incorporating the additional TCM BIP function that enables to locate error sources in multi-domain networks. FEC corrected symbol rate can also be used as a degradation monitoring tool with the advantage that correction actions can be initiated even before any actual service degradation is perceived by the users.

Delay measurement has always been a more difficult task. SONET/SDH does not provide standard in-service delay measurement tools and as a result only sporadic out-of-service measurements can be taken. Another option is to rely on higher telecommunication layers to measure the delay, but then it is very difficult to isolate the delay component being contributed by each subtending layer to the overall measured delay.

Delay sources.

In an OTN network the main delay sources are:

- Optical fiber delay – approximately 5µsec/Kilometer
- Equipment delay – FIFOs

Note that since OTN is a deterministic transport technology there is no congestion related delay variation.

Delay variation for an operating system can be related to:

- Temperature variations
- Route changes
- Equipment configuration changes
- Equipment replacement

OTN Delay Measurement (DM) function.

In order facilitate in-service delay measurement, a new function was added to the OTN overhead. This function reuses one of the formerly reserved bytes in the ODU overhead as shown in Figure 1.

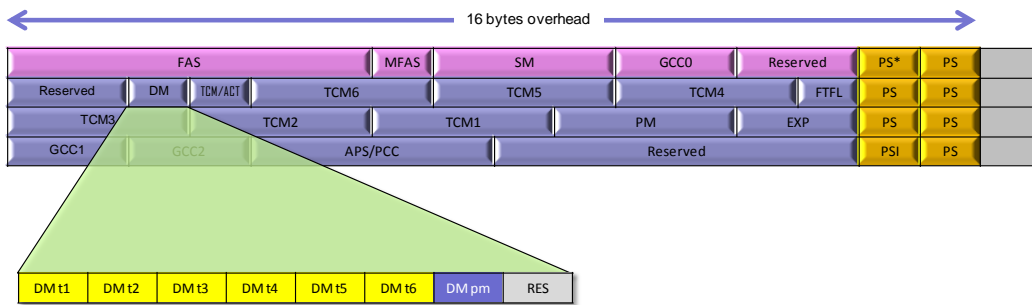

Figure 1: DM field

Delay is measured by transmitting a known pattern in the selected bit of the DM filed, and measuring the elapsed time until the pattern is received back as shown in Figure 2.

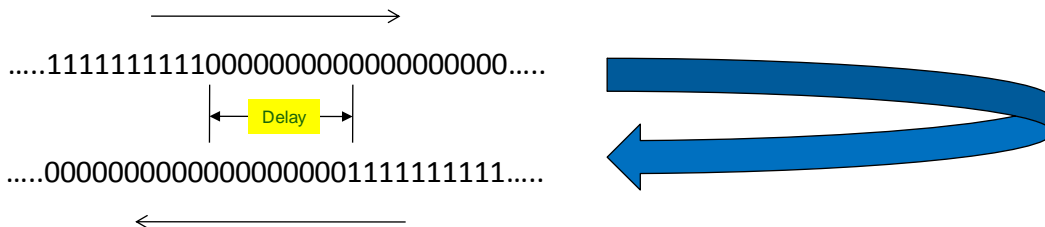

Figure 2: Delay measurement pattern

Note that the measured time is the Round Trip Time (RTT) between the measuring points as shown in Figure 3. Since the DM field appears once in every OTN frame, the delay measurement accuracy is in the order of an OTN frame which in turn is relative to the measured OTN signal rate.

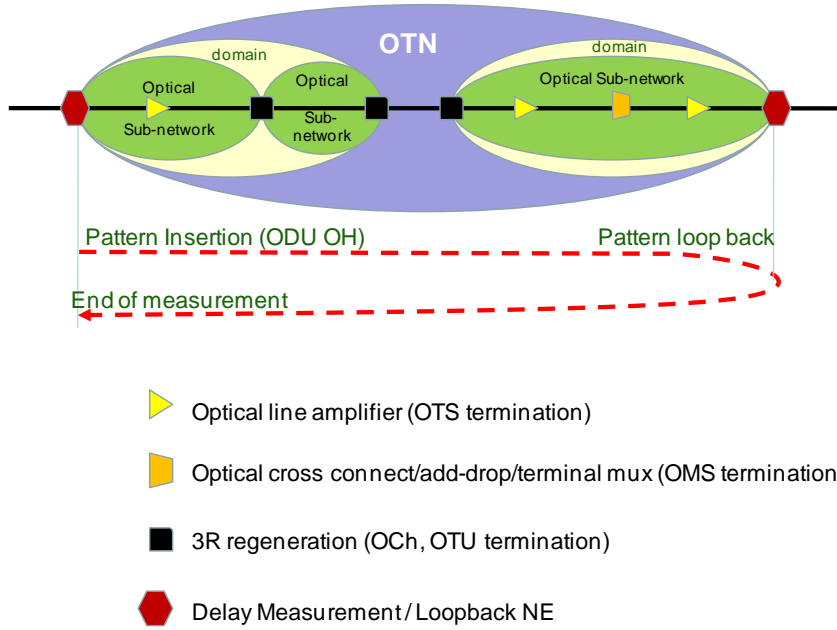

Figure 3: RTT delay measurement

As can be seen in Figure 2 a bit in the DM field is assigned to each TCM level, and one is assigned to the ODU path. With this scheme the delay of each domain (Figure 4.a) as well as the end- to-end delay (Figure 4.b) can be measured.

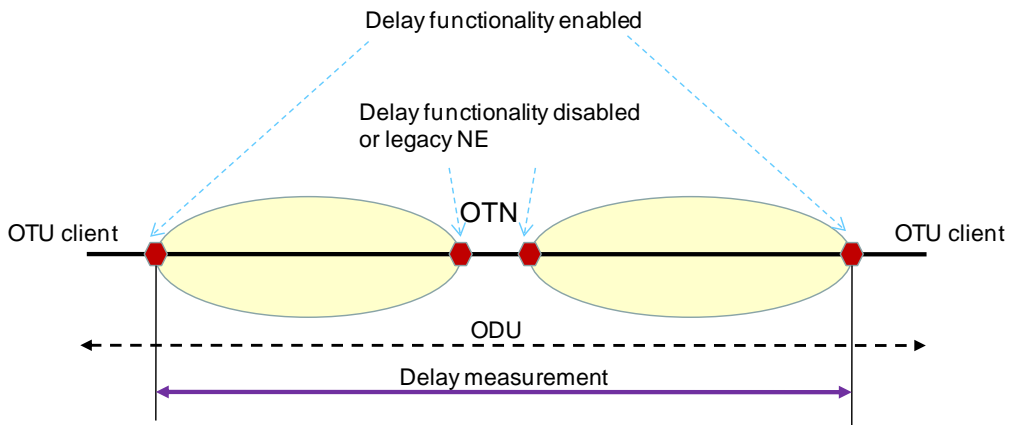

Figure 4.a: Domain delay measurement

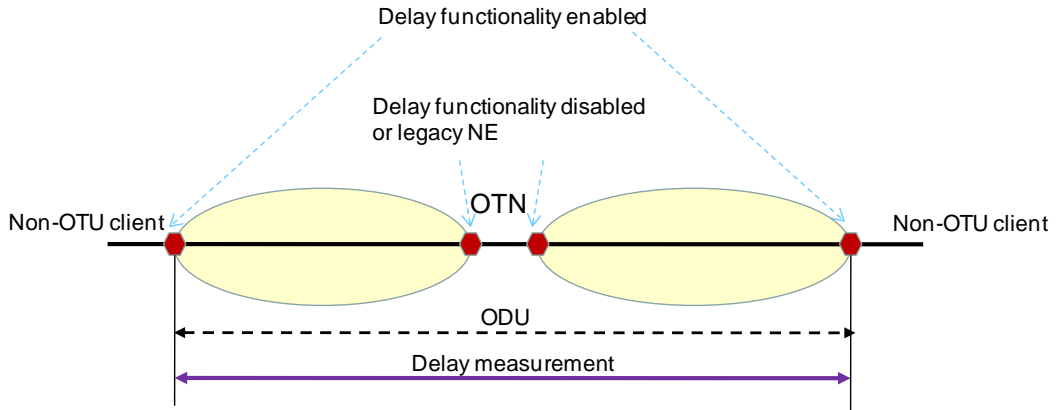

Figure 4.b: End-to-end delay measurement

DM state machine

Figure 5 shows the state machine used by a management element in order to implement the DM function. Delay can be measured on a continuous basis since the measurement itself does not impact any other functionality, and it can be simultaneously measured for all TCMs and for the end-to-end path. However, since delay in optical networks is almost stationary, changing at a very slow pace, we envision that the DM will be activated only periodically for each path and for each TCM.

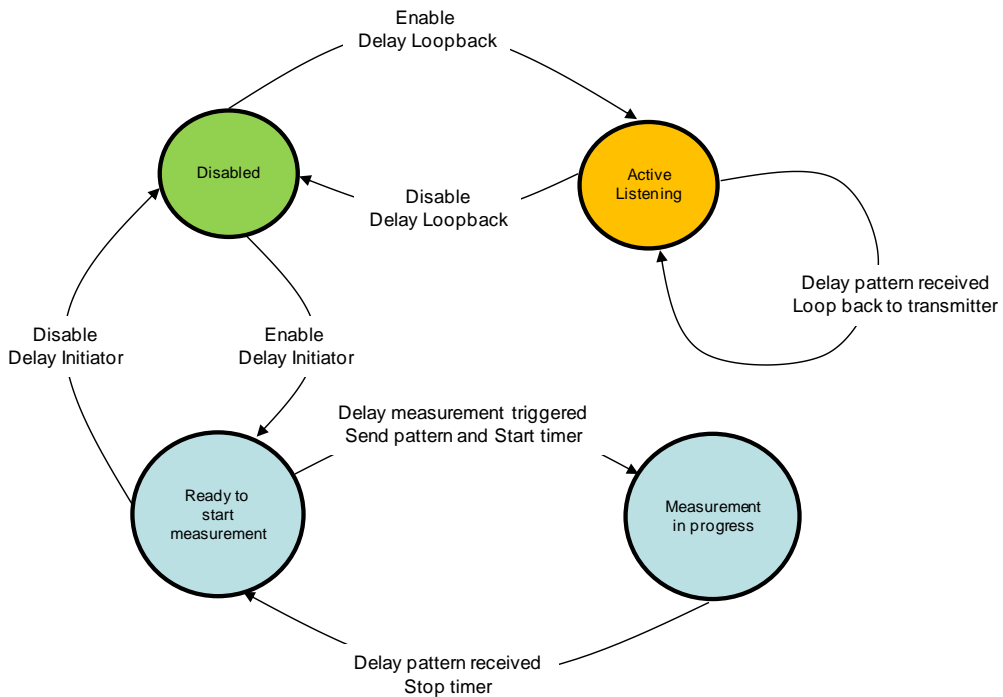

Figure 5: DM state machine

One way delay measurement

In OTN networks since usually a path is bidirectional, both path directions follow the same route, and the delay is not influenced by the network state (congestion), one way delay may be reasonably approximated as $\sim RTT/2$.

Care should be taken though when unidirectional path protection is being provided for the path under test. When using unidirectional protection only the failed direction will be re-directed to the protection facility, thus possibly routing each path direction through a different route, as shown in Figure 6.

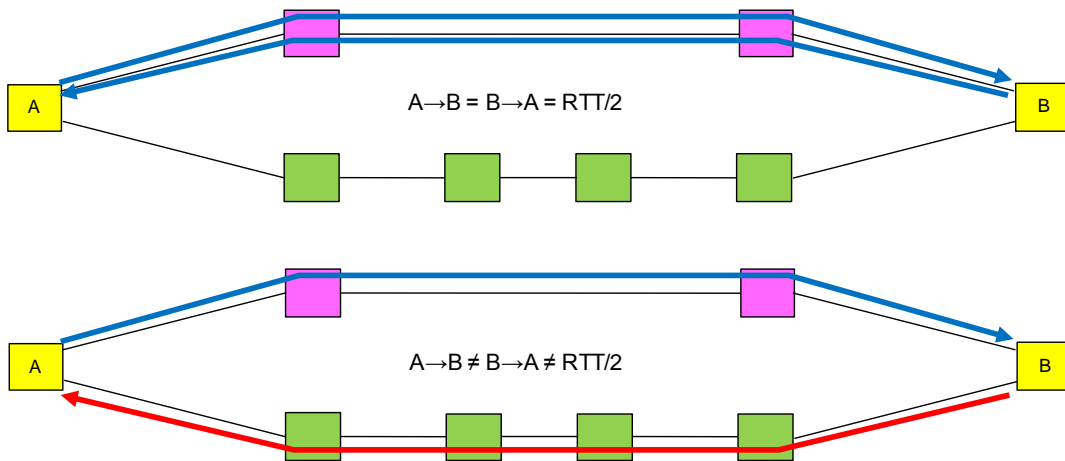

Figure 6: Unidirectional protected path

Apodis

In order to facilitate delay measurement in OTN networks IP Light has incorporated in Apodis the required features to support DM. Using Apodis based systems users can measure delay on any interface, at any OTN level and for any of the TCMs as well as for the end-to-end path. A DM function is provided for each Apodis interface which can be activated independently and in parallel with the DM function of other interfaces. Furthermore, users can program the selected byte for DM (the field defined by the standard being the default) and the character to be sent and monitored.

To use the Apodis DM feature the user selects the OTN level and the desired TCM or end-to-end path, programs DM loop back in the remote end-point Apodis, and writes the DM character. Once the character is received back by the test initiating Apodis it issues a positive indication, including an associated maskable interrupt, and provides the measured delay. Bits within the DM field that are not being used for the DM function can be transparently passed through, supporting nested TCM schemes.

About IP Light:

IP Light is developing Apodis, a product family of leading edge OTN processors designed to facilitate the introduction of new OTN capabilities and service applications.

IP Light is headquartered at 4 Hashiloach St. POB 7209, Petach-Tikva, 49520, Israel

Office: +972-3-7217810

Fax:+972-3-9215076

info@iplight.com